

The design and development of stop motion armature for a wide variety of applications

ABSTRACT

The development of prototype stop-motion armatures for a wide variety of applications commonly involves the use of metal, stainless steel, and brass. This research aimed to design stop-motion armatures using new materials and concepts for both basic and advanced stop-motion animations and to design the armatures to be fit and relevant to the characters that were made according to physiology and flexibility in use with a variety of functions. The present research used research samples consisting of 6 experts in materials, industrial designers, and designers of animation movies. They were asked to examine, edit, and evaluate the product prototype. The instruments used in the research were in-depth interviews and questionnaires. The data were analyzed by using mean and standard deviation. The results of the research are as follows: 1) regarding the development of stop-motion armatures, there were 9 armature models; 2) based on the research, test, and experiment, the suitable material was polyamide or nylon plastic, which is flexible and durable. It was good for the movement and forming of the position of the characters firmly; 3) regarding the test of efficiency for these armatures, the overall evaluation was at a high level. The mean score was 3.52, while the standard deviation (SD) was 0.43. The design of these stop-motion armatures shows a distinctive point in that they can be produced in industrial systems with a large number of items made at the same time. Further, this production process makes the armatures able to be fully modified or adjusted according to the characters designed.

KEY WORDS

Armature, stop-motion, animation, industrial design

Visit Janma 

Janyut Srihirun 

Naresuan University,
Faculty of Architecture Art and
Design, Department of Art and
Design, Phitsanulok, Thailand

Corresponding author:

Janyut Srihirun

e-mail:

kaijanyut@hotmail.com

First received: 5.5.2022.

Revised: 25.6.2022.

Accepted: 4.7.2022.

Introduction

"Economy is driven by innovation" is an expression that implies the economy creates wealth through science and technology, culture, and creativity. It also creates products that are "innovative" in order to adapt and respond to changing economic conditions. Increasing the capacity of technology and innovation, creativity, and business leads to intellectual property, added economic value, and meeting the needs of the labor markets, both domestically and internationally. Nowadays, the animation media market is considered the main media for disseminating, persuading, and presenting the cultural

stories and civilization of nations (Liu, 2007). Animation is a universal media that can be accessed by people of all nations and languages. Although each nation and culture may have a different language, animation is a visual language that is expressed through personality, gestures, facial expressions, and emotions, making it something that is easy for viewers, both children and adults, to understand. This makes animation popular, and people of all ages appreciate it. In addition, it is also prevalent like movies that are part of the language (Kivy, 2004).

Stop-motion is another animated filmmaking technique that helps to convey the story of the animation. In the

past, studies of robotics and computer graphics were significantly accepted in the description of movements of stiff body by using armatures for the animation characters (Singh & Singla, 2016).

To be completely successful, it is impossible to ignore or overlook the importance of anatomy when designing characters, both in the structure of people and other creatures. For example, when a steel company wants to create armatures and mechanical tools of dragon characters, it needs to use specific steel tools, have expertise, and be well trained in the use of steel working tools, which may be apart from animation work. It is because these aspects are necessary to be used in working on rotating joints and ball joints at the wrist and elbow axis. This requires consultation with knowledgeable and experienced experts who work in the steel-making industry and cutting work since it will help to improve the work to be better and faster. These experts work at full capacity with intelligence and knowledge so costs can be controlled appropriately. However, these experts are not stop-motion designers, so they cannot give recommendations about anatomy, creating the characters properly, or the working of the muscles covering the mechanics structure for the rotation and elbow movement at various pivot points and behind the elbow that there are more points than the wrist pivot points. These qualities require the ball joints to be made, and this mechanism is a very active form in the armatures that can create curving, twisting, and moving muscles that are made from foam, which finally covers the entire structure of the armatures. This is a realistic style of work creation.

There is also the observation about how to make the armatures (skeleton) fit and relevant to the designed characters. It can be observed from the moving joints and the bending of the muscles from the skeleton that creates the mechanical system used for the armature. It is controlled and performed in an anatomical form, which creates physical characteristics and the personality of the characters. Regarding the forms of the hand and leg systems created for people, horses or dogs, before designing various parts of the mechanical system, it needs to be studied, analyzed, and researched to understand the physiology. This study aims to answer the question and solve many doubts about character design by sketching the characters. Besides, this can help to understand various perspectives and proportions as well as provide clarity. Importantly, the muscles will change their shapes when twisting and turning for the continuation of the arms in rotation, so it is also necessary to make the pivot point around the elbow rotate back. This results in the armatures being able to twist their arms and latex foam, which is a type of rubber used to make the texture of the armature, and be bent like the real muscles of living things. If it is not possible to create a pivot point at the elbow area, but create the twisting of the arm around the wrist movement, it will cause a

very tight twist on the wrist, which does not correspond to reality or the nature of the design of the armatures. Moreover, the joints must not be overlooked or abandoned in the designing and making of characters. It is crucial to understand anatomy, motion, and complete movement. As can be seen from world-renowned sculptors such as Michelangelo and Rodin, artists provide good examples of masterpieces that arouse people's interest and express the differences in concepts, forms, methods, and eras as well as the decision-making process for creating each masterpiece (Brierton, 2002).

For the reasons mentioned above, the researchers aimed to develop a prototype for a stop-motion armature that could be used in a wide variety of applications. Generally, they are made of metal, stainless steel, and brass. This requires expertise in the use of hand tools for various metal work and the design of stop-motion armatures for those who are not experts or work in metal work with new materials and concepts developed for stop-motion animation, both basic and advanced levels. Besides, the armatures must be designed to fit and respond to the personality of the designed characters according to the physiology and flexibility in use with a variety of functions.

Research objectives

1. To study and analyze stop-motion armatures for animation work that can be produced in an industrial system
2. To develop and design stop-motion armatures for animation work and develop materials and production processes suitable for the industrial system
3. To evaluate the efficiency of the prototype stop-motion armatures

Literature review

The researchers reviewed, synthesized, and analyzed 12 patterns/models of armatures in the markets before designing and developing the stop-motion armature in the present research, as shown in Table 1.

From Table 1, the researchers selected and compared 12 stop-motion armatures for a review to identify their characteristics, strengths and weaknesses, and uniqueness of the armatures as preliminary information for the design of the new structure of the armatures in order to be unique, find the differences, and develop a usability based on the reviewed stop-motion armatures. The data are summarized in Table 2.

Table 1 (part 1)

A summary of material and property analysis and parts of 12 stop-motion armatures



| Armatures | Armature Forms | Materials | Strengths | Weaknesses | Joint Forms |
|--|---|--|--|--|--|
| 1. Cyclops (Harryhausen, n.d.) |  | It was made of metal with joints on the body parts consisting of steel balls. The head is made of resin plastic. | The materials used are strong and durable. | The overall structure is fixed and created for one character only. It can easily rust. | All joints are steel balls, and the sockets are iron sheeting attached with welded bolts. |
| 2. Armature by Ted Sydor when he was a student at Middlesex County College, New Jersey in 1991 (Trik Film Effects, 2010) |  | It was made of plastic and wood, about 10 inches tall, using bolts to hold the parts together with the use of plastic ball joints. | The structure is easy to assemble by hand. | Plastic sheets at the joints are easily twisted. The ball joints are plastic, causing the rotating joints to have a lot of friction. | All joints are plastic balls, and the sockets are made of plastic sheets connected by bolts. |
| 3. Armature (Brierton, 2018) |  | It was made of various metals such as aluminum, steel and materials used to build spacecraft, which are lightweight, highly durable, and flexible; 50% lighter than aluminum. | The materials used are strong and durable. | It has a specific and fixed structure that is difficult to assemble, requires cutting tools to cut according to size, and must be assembled according to the design model. | All joints are aluminum balls, and the sockets are made of aluminum sheets connected by bolts. |
| 4. Armature (Kawamura, 2019) |  | The main structure is aluminum, the socket is made of phosphor bronze plate, and the ball head is made of ordinary steel, which is rust-proof. | The materials used are strong and durable. | It has a specific and fixed structure that is difficult to assemble, requires cutting tools to cut according to size, and must be assembled according to the design model. | All joints are aluminum balls, and the sockets are golden phosphor bronze plates connected by bolts. |
| 5. Armature (Animation Toolkit, 2018a) |  | It is polished stainless steel with 24 joints. Many points were designed according to anatomical design and 3D printed muscle structure. | The internal structure is polished stainless steel, which is strong and durable. | It has a specific and fixed structure that is difficult to assemble, requires cutting tools to cut according to size, and takes a lot of time to assemble. | All joints are stainless steel balls, and the sockets are stainless steel plates connected by bolts. |
| 6. Armature Creature Kit (Animation Toolkit, 2018b) |  | It is made of more than 100 pieces of stainless steel, 20 rust-proof type metal joints, hardened stainless steel ball head, and socket head bolts that have magnets embedded at the tip of the foot. | The materials used are strong, durable, and lightweight. | It has a specific and fixed structure that is difficult to assemble, requires cutting tools to cut according to size, and takes a lot of time to assemble. | All joints are steel balls, and the sockets are stainless steel sheets attached with bolts. |

Table 1 (part 2)

A summary of material and property analysis and parts of 12 stop-motion armatures



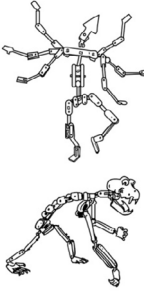
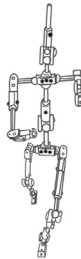
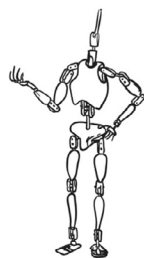
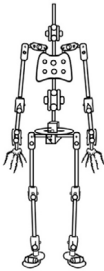

| | | | | | |
|---|---|---|--|---|---|
| <p>7. Stikfas (LNCollections LLC, 2008)</p> |  | <p>It was made of hard plastic from Hasbro's industrial plants, with plastic pieces that are easy to make and change.</p> | <p>The Stikfas has all the ball joints, and the sockets are easy to make and assemble, but not easy to fall off.</p> | <ul style="list-style-type: none"> - The posture and movement are not very good since the socket supports one-sided bend only. - The joints are not fully bent and folded, such as the folding of the knees that can be done only 30-45 degrees. - There are no clavicle bone joints or finger joints. | <p>All joints are balls. The sockets are balls sized 2.5 mm wide.</p> |
| <p>8. Modibot (ModiBot, 2019)</p> |  | <p>It was created from 3D printing, which can use a variety of plastic filaments, such as PLA, ABS, including printing with resin plastic.</p> | <p>In 3D printing, a variety of materials can be chosen for use.</p> | <ul style="list-style-type: none"> - The posture and movement are not very good since the socket supports one-sided bend only. - The joints are not fully bent and folded, such as the folding of the knees that can be done only 60-90 degrees. - There are no clavicle bone joints or finger joints. | <p>All joints are balls. The sockets are the same big and thick in all parts so that they can be connected in a variety of sizes. The ball size is 6 mm. The socket balls are 8.5 mm in size.</p> |
| <p>9. Stickybones (Stickybones Inc., 2019)</p> |  | <p>It was created from a 3D program and printed with a resin printer. After that, it was scrubbed to smooth the surface, painted, and lasered to make the colors more firm and durable.</p> | <p>A variety of gestures and postures can be set up. Knees and arms can be bent and folded up to 10-15 degrees.</p> | <ul style="list-style-type: none"> - The overall structure is the same size as human proportions, which are fixed in appearance and unchangeable. - The hands and feet are bigger than the actual human physique. | <p>All joints are balls. The sockets are large and thick at specific points, especially the parts that support weight, such as the feet, chest and waist. The joints of the fingers are small and have all 5 fingers.</p> |
| <p>10. Armature Nine (A9-RIG) (A9 Products, 2020)</p> |  | <p>The surface is a combination of a variety of materials, such as wood composite, and is produced from 3D printing using ABS plastic. The joints are made from resin 3D printing.</p> | <ul style="list-style-type: none"> - Most joints are ball joints, and the sockets, except for the knees, use bolts to increase the strength. - It looks like a real human. There are joints on every finger. | <p>The joints are more than necessary. The clavicle bone joints and thigh joints are too large, so it is not very easy to move.</p> | <ul style="list-style-type: none"> - The head joints, arms, fingers, and ankle joints are balls and sockets. - Clavicle bone joints and pelvis joints are serrated spurs and can be rotated in 2 directions. The other side is a ball socket. - There are 2 types of knee joints: the top is the ball and the socket, and the knees are plastic sheets connected by bolts. |
| <p>11. Gemobot (Nattotoys, 2017)</p> |  | <p>The surface is printed with ABS plastic. The joints are metal ball joints. The hands are made of flexible plastic.</p> | <p>The movement of the steel balls and the plastic sockets work well, with inertia acting on ABS plastic.</p> | <ul style="list-style-type: none"> - The bending of the knees and elbows is not very good, and it can only be folded to a minimum of 45 degrees. - The body cannot be bent since it is a square that has angles that make it unable to bend. | <p>All joints are steel balls, and the sockets are plastic with a central notch.</p> |
| <p>12. Skelly the Skeleton (Lane, 2018)</p> |  | <p>It was created from 3D printing, which can use a variety of plastic filaments such as PLA, ABS, including printing with resin plastic.</p> | <p>In 3D printing, a variety of materials can be chosen for use.</p> | <ul style="list-style-type: none"> - There are no clavicle bones, and the neck is unable to bend. - The pelvis is too narrow, so the socket cannot rotate the leg. - There are no finger joints. | <p>All joints are balls. The sockets are big and thick. All joints are equal, which allows them a wide range of connections.</p> |

Table 2

The comparison of 12 stop-motion armatures and the armature designed in this study

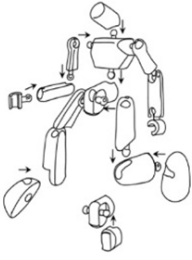
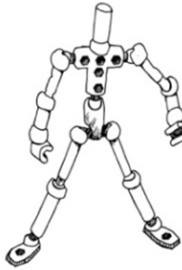
| The main design features of the 12 stop-motion armatures | The comparison of these 12 stop-motion armatures and the armature designed in this study |
|---|--|
| 1. The joint is a ball head, and it is a joint. | 1. There is no difference in this point. |
| 2. The material is strong and resistant to bending and moving of joints. | 2. There is no difference in this point. |
| 3. The metal materials such as iron, copper, aluminum were used. | 3. The designed armature was experimented with metal and plastic materials, such as stainless steel, PLA plastic, and rubber. The problem is that the production cost will be higher in the whole working process, mold material, and working time |
| The main design features of the 12 stop-motion armatures | The comparison of these 12 stop-motion armatures and the armature designed in this study |
| 4. Shape, proportion, and height must be produced and created only for each character. | 4. The shape, proportion, height, and width of the designed model can be modified. |
| 5. The Armatures made from various metals require high craftsmanship skills in metalwork and can be built at a high cost and time consuming with a low production number. | 5. The designed armature can be manufactured as a prefabricated part which can be assembled without requiring very high building skills and can be produced in industrial system with a high number. |
| 6. Some new materials have been developed to be produced massively and industrially. | 6. The designed armature was tried out with new materials, such as PLA plastic and nylon plastic in the production. |
| 7. The folding joints, such as elbows and knees joints generally cannot be bent up to 180 degrees. | 7. The folding joints, such as elbows and knees joints are developed to be bent up to 180 degrees. |

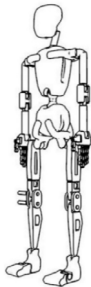
Research method

This research has developed and designed a stop-motion armature for animation work so that it can be produced in an industrial system. The design process required a stop-motion armature for people who did not have knowledge and expertise in a metal-working field. In addition, it required flexibility in a variety of functions and a uniqueness in design. The details of the research process are as follows.

Step 1: To study and analyze stop-motion armatures for animation work that can be produced in an industrial system

It started with reviewing documents, textbooks, research findings, research methods, and designing and making processes related to stop-motion armatures. 12 models of armatures from armature structure companies and films in the markets were chosen, synthesized, and summarized. The design framework was then created to be different and unique. After that, the interviews with 2 experts in designing animated films using stop-motion techniques and 1 industrial designer were conducted. The examples of the in-depth interview questions are: 1) What are the problems and needs for materials and the design of stop motion armatures? 2) What are the features of the stop motion armature design?, and 3) What precautions do you have in the industrial production system regarding the design of stop-motion armatures? The researcher then analyzed the data obtained from the interviews and presented them in a descriptive form.

Step 2: To develop and design stop-motion armatures for animation work and develop materials and production processes suitable for the industrial system

After the conceptual framework for the design of stop-motion armature was made, and the in-depth interview data were obtained, these data were used to select the material and design together with various material experiments to use in the prototype armature. The experimental materials were ABS plastic, PLA plastic, and Nylon plastic which are materials commonly used for 3D printing and stop-motion armatures. Additionally, these materials were suitable for use in injection molding in industrial production systems. Then, the product prototype was made using 3D printer technology (Loy, 2018). Fused deposition modelling (FDM) and LCD 3D Printer were employed and experimented with metal materials, including stainless steel, aluminum, UV resin, and rubber materials. There were 9 different models. These models were then tested and evaluated by in-depth interviews with 4 experts consisting of 1) 2 animation designers, 2) 1 animation director, and 3) 1 product designers. Data obtained from the interviews were summarized. One model of stop-motion armature was selected, developed, and edited in the final stage.

Step 3: To evaluate the efficiency of the prototype stop-motion armatures

After developing and editing the prototype, a 3-minute stop-motion animation was made in order to test the movement of the armature and find a development conclusion. The results were then evaluated by using a Likert

Scale questionnaire by 6 experts consisting of 2 animation designers, 2 animation directors, and 2 product designers. The evaluation was emphasized on 4 aspects, including the design process, the usability of stop-motion armature, the determination of posture and movement of the stop-motion armature, and the standard of the production and development of the stop-motion armature. The data were then analyzed quantitatively.

Results

The research findings are shown below according to the research phases mentioned above.

Regarding Research Objective 1, it was found that, in terms of shape design, there were shapes that were the same as human proportions and could be adjusted according to the character design. For example, 1) in the joint areas, the main parts were the ball joints and the ball sockets for the movement around the joints, 2) parts of the elbows and knees could move freely and follow the natural movement of living organisms, as found in Janma (2003), and 3) the materials mostly used from research studies in stop-motion animation industry were metal, such as aluminum, stainless steel, and brass, followed by PLA plastic, which has elastic properties and is resistant to friction.

Regarding Research Objective 2, the researchers designed 9 stop-motion armatures and experimented with different materials, beginning with plastic. From the concepts and rationale supporting designs that require a large amount of industrial production, it was reinforced to use aluminum materials in ball joint parts for adding strength and being resistant to friction between the joints when moving. After that, the researchers developed the stop-motion armatures by adding plastic materials that are flexible and resistant to twisting, folding, and bending when moving. Consequently, it came into the final form based on the advice of experts and consultants as well as agreement. That is, the researchers should use only nylon plastic material in the production of the armatures according to the reasons mentioned above.

After that, the researchers did a sketch design by taking the form of the bone structure and the human anatomy as a guideline for drafting and developing in order to be similar in terms of shape, proportion, function, and various movement methods of parts around the joints, as well as the main bone parts in the human body structure and other bipedal animals. This made the design work similar to the skeleton structure and the armatures studied. However, new concepts were also added regarding the need for the armatures to be designed with the ability to be modified with flexible proportions and adjustable for height- low to get the

desired size, while the proportions in the characters could increase or decrease by themselves, such as the length of the arms, legs, neck or body. In designing the stop-motion characters, the users would be able to increase the number of different sections of the body, such as adding more than two arms, legs, or wings to the characters as well as adding head and tail parts. This aimed to increase the functionality of the stop-motion armatures and provide greater flexibility in the design. Moreover, it enabled the creation of animation work with new character designs. Finally, the designed armature was developed as shown in Figures 1-3. These stop-motion armatures are independent and can be adjusted and modified further, such as height proportion, the number of additional arms and legs, and additional parts such as tails and wings. This is considered a new design that is different from those currently available on the market.

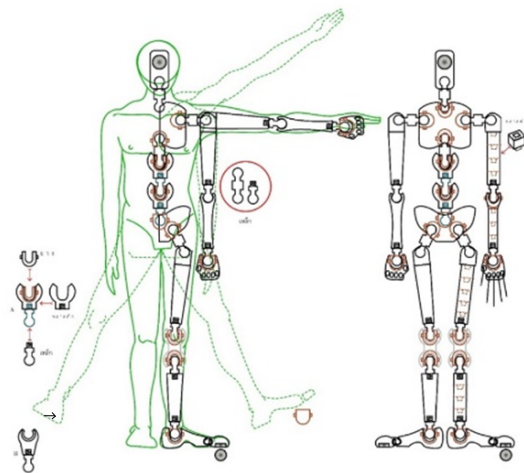

» **Figure 1:** *Sketched and designed work for the stop-motion armature*



» **Figure 2:** *Final designed work of the stop-motion armature*

The concept of the design, function, and features of various parts of the stop-motion armatures that were redesigned and developed are as follows.

- The head and head area of the armatures can be adjusted in terms of size and proportion by having a slot as an extension to increase the height. From this concept, it can be adjusted according to the work of various character designs, as shown in Figure 4.



» **Figure 3:** Stop-motion armatures that are independent and can be adjusted and modified

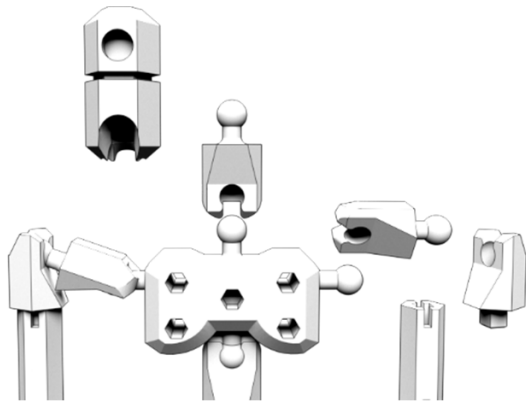

» **Figure 4:** Details of head, chest, and shoulders of the stop-motion armature

- Shoulder joints, thigh joints, and the parts in this area can be substituted, as shown in Figure 5. In Figure 6, the structural ball joints can be connected to ball joints with ball socket holes. These joints are the same joints. They can be adjusted into shoulder joints, knee joints, elbow joints, and all foldable joints. Also, the adjustment of the angle to the position of the joints can be done to an incremental angle of more than 180 degrees. According to the reviews in Table 1, most of the joints will be angled around 180 degrees or less.

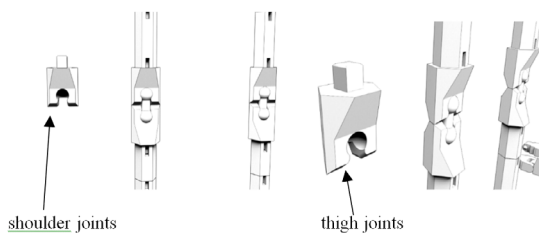

» **Figure 5:** Details of the shoulder joints, thigh joints, and parts in this area that can be replaced

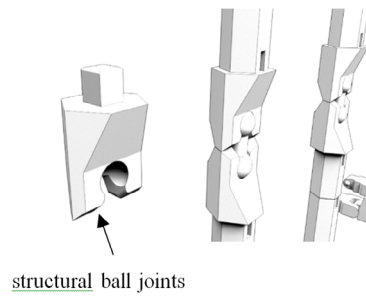

structural ball joints

» **Figure 6:** The structural ball joints that can be connected to ball socket holes

- The joints that determine the proportions of the arms and legs can be adjusted to increase – decrease the proportion of the length and height of the character according to the designer's preference. In addition, the spine parts can also be adjusted to increase- decrease the height of the character, as seen in Figure 7. The important parts that have been designed and developed make the characters adjust more easily since there are joint pieces that can adjust the height and add organs. Figure 8 shows the sizes and proportions of the armature in greater detail in millimeters.

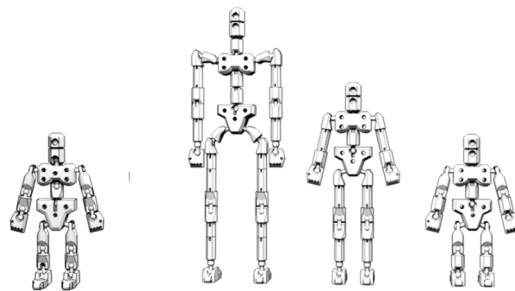

» **Figure 7:** The joints that can be adjusted to increase or decrease the proportion of the length of arms, legs, and the height of the spine

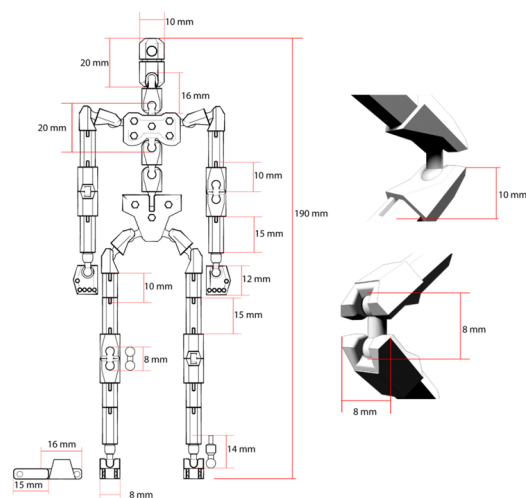

» **Figure 8:** The sizes and proportions of the armature in millimeters

- The joints on the elbows and knees in this new design use the concept of physical work. The elbows and knees are designed to bend more specifically to 180 degrees. The design of the joints that wear to the ball can bend more than other joints in order to increase the realism of posture, which can make the armatures move more effectively, as shown in Figure 9. Figure 10 shows the structural parts of the hips, hands, and thigh joints.

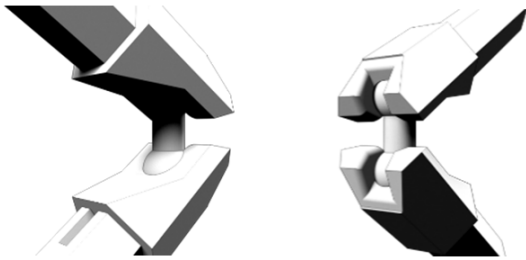

» **Figure 9:** Elbow and knee joints that can be bent more around 180 degrees

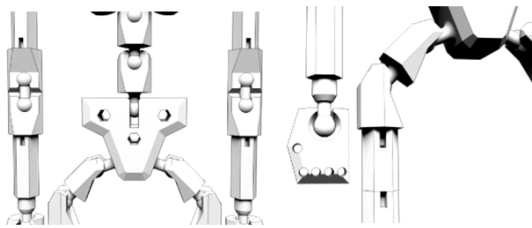

» **Figure 10:** Structural parts of the hips, hands, and thigh joints

- For foot pieces, the length and width can be adjusted according to the length of the character's feet, as shown in Figure 11.

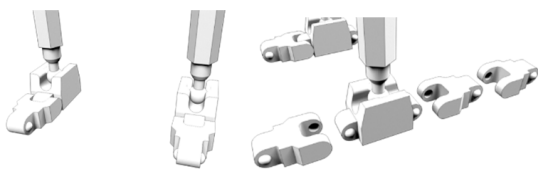

» **Figure 11:** Foot parts and additional parts

- When the prototype had been obtained from a 3D printer, the researchers there after studied the production process and mold design of the stop-motion animation at the industrial level. The researchers chose to use the injection molding process. The principles of the injection molding production process can be explained as follows. Firstly, it started with adding raw materials such as plastic granules or powder into the filling cone. In this research, polyamide or nylon plastic

was used to be sent to the front of the cylinder, which has an electrical heating plate that causes the plastic to melt and be forced to move to the tube through the nozzle and into the mold, which is closed. The mold, which is cooled by cold water produced from a chiller, will cool and harden the workpiece, allowing removal of the mold from the model in a short time. Then, the work is sent to decorate, as seen in Singh and Verma (2017). In this research, nylon material was chosen because this type of plastic has outstanding properties in terms of strength, toughness, tensile resistance, and resistance to corrosion as well as abrasion. It is not easily deformed, making it suitable for very strong work. In this research, there were many components (joints) that needed to be assembled to use in moving the armatures many times. Therefore, it was necessary to use plastic that is resistant to friction among the joints, which would affect the strength and durability of the stop-motion armatures.

After that, the researchers created the industrial drawings of the stop-motion armatures and the mold of the stop-motion armatures, as shown in Figure 12, which is a mold for casting an armature designed for mass production with nylon material injection molding and bringing the sub-parts together to form a complete full-body armature. The researchers also filed a patent for the armature and the mold made in Thailand as a research innovation.

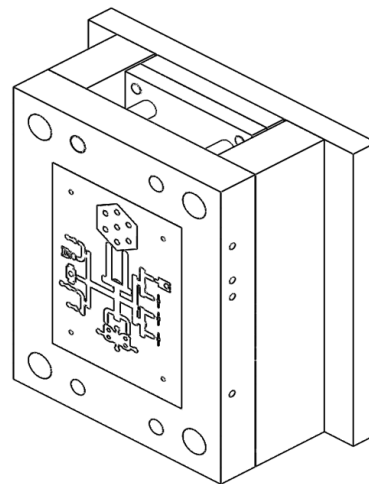

» **Figure 12:** Injection molded parts designed in this research (Injection Molding)

Regarding Research Objective 3, the results of testing and evaluating of the stop-motion armature prototype from research advisors and experts are presented below. For the results of testing the postures and movement (animated), it was found that this designed armature could determine the motion, arrange movements frame by frame in order to be arranged in an editing

program, and create animation. This led to the illusion that the stop-motion armatures could move and be lively as characters designed to express emotions, postures, movements, and gestures. In this experi-

ment, the researchers determined the basic movements needed to create movement, such as walking and running by the armatures, with different shapes and proportions, as shown in Figures 13 and 14.



» **Figure 13:** Example of determining the basic movements as Walk Cycle armature



» **Figure 14:** Example of determining the basic movements as Run Cycle armature

The assessment criteria of the stop-motion armatures prototype design were divided into 4 aspects: 1) the design process, 2) the usability of stop-motion armature, 3) the determination of posture and movement of the stop-motion armature, and 4) the standard of the production and development of the stop-motion armature as shown in Figure 15. The results of evaluating of the stop-motion armature prototype from research advisors and experts showed that the overall effectiveness was at a high level ($\bar{x}=3.52$, $SD=0.43$).

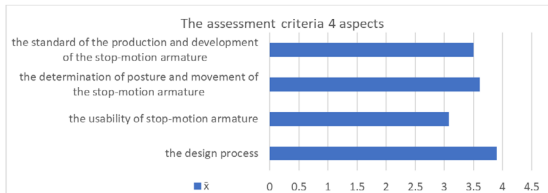

» **Figure 15:** *The assessment criteria 4 aspects*

When considering in greater detail, the results of each aspect are as follow.

1. Regarding the design process, the overall effectiveness of the stop-motion armature was at a high level ($\bar{x}=3.9$, $S.D.=0.60$). When looking in greater detail as shown in Figure 16, the material selection was rated the highest ($\bar{x}=4.2$, $S.D.=0.54$). It was followed by its usability ($\bar{x}=4.0$, $S.D.=0.65$), the development design for properties of stop-motion armature in terms of physical features ($\bar{x}=3.9$, $S.D.=0.38$), and its durability ($\bar{x}=3.64$, $S.D.=0.79$), respectively.

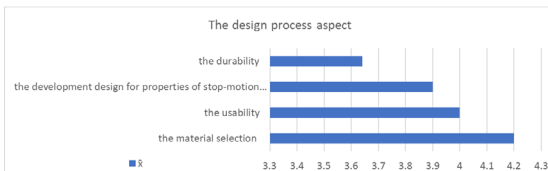

» **Figure 16:** *The design process aspect*

2. Regarding the usability of stop-motion armature, the overall effectiveness was at a medium level ($\bar{x}=3.08$, $S.D.=0.45$). When looking in greater detail as shown in Figure 17, the practicality was rated the highest ($\bar{x}=3.19$, $S.D.=0.44$). It was followed by the easiness of material using ($\bar{x}=3.07$, $S.D.=0.32$), the appropriate using process ($\bar{x}=3.04$, $S.D.=0.44$), and application to other work designs, such as product design and craftsmanship design ($\bar{x}=3.02$, $S.D.=0.60$), respectively.

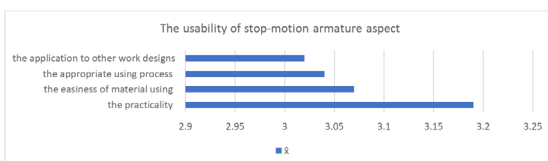

» **Figure 17:** *The usability of stop-motion armature aspect*

3. Regarding the determination of posture and movement of the stop-motion armature, the overall effectiveness was at a high level ($\bar{x}=3.61$, $S.D.=0.45$). When looking in greater detail as shown in Figure 18, the flexibility to modify posture, contraction, restoration, and character posture features of the stop-motion armature that can convey emotions and meaning of the character the highest ($\bar{x}=3.7$, $S.D.=0.31$), It was followed by the suitability of material for stop-motion technique ($\bar{x}=3.64$, $S.D.=0.51$), and that the material can help to move and determine the posture according to the designer's needs ($\bar{x}=3.49$, $S.D.=0.53$), respectively.

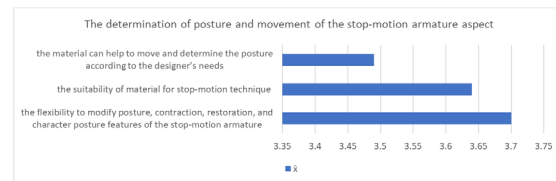

» **Figure 18:** *The determination of posture and movement of the stop-motion armature aspect*

Moreover, in moving the joints and posturing this animated stop-motion armature, the researchers had moved the joints more than 1000 times (estimated by movement postures of proportions to generate 25 frames per second). For the movement postures, both walking (Walk Cycle) and running (Run Cycle), the amount of each movement was approximately 30 seconds (30 x 25 frames equal to 2 movements, moving more than 1500 times). The firmness, stability, not expanding the size of various joints, and frictional resistance without breaking, bending, cracking were achieved without any effect on this stop-motion armature. This confirms that plastic materials such as Nylon are suitable for use.

4. Regarding the standard of the production and development of the stop-motion armature, the overall effectiveness was at a high level ($\bar{x}=3.50$, $S.D.=0.23$). When looking in greater detail as shown in Figure 19, the practicality in the industrial system production was rated the highest ($\bar{x}=3.60$, $S.D.=0.25$). It was followed by the suitability to be produced for sale ($\bar{x}=3.40$, $S.D.=0.21$).

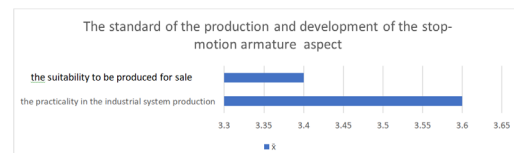

» **Figure 19:** *The standard of the production and development of the stop-motion armature aspect*

In this research, there are suggestions for further research as follows.

- The shoulders are too convex. As a result, they will tear when covered with plasticine. Therefore, the surface should not be smooth so that there will be more adhesion of the plasticine and other materials.
- It should be used and broadcasted as a short film, including showing the making of these designed armatures (behind the scenes).
- It should be applied to use with a variety of materials, such as plasticine, silicone, and so on.

Conclusion and discussion

In this study, there was a clear objective in terms of designing the stop-motion armatures in order to be able to be produced in large numbers at the same time and be suitable for industrial production in terms of design, shape, and materials used. Besides, the design is different from general armature designs that are available in the market and in the industrial system. That is, these stop-motion armatures can be modified, adjusted, modified for height- low proportions, and given additional parts such as arms, legs, tails, wings, and various functions, which can be changed appropriately and freely according to the shape and proportion of the character designs by designers and animators. As Harryhausen and Dalton (2008) noted, many great movies use animation for the characters' movements. It takes a lot of time in order to find the best process techniques, practical guidelines, and methods that are appropriate according to the desired concept. This is in line with Shen (2007), who said that using technology and tools is just one way to communicate the main story, convey the social and cultural meaning, and create cultural meaning through varied understanding of visual media by observing the true story in order to support the traditional ideals and Western concepts that movies attempt to convey as reality.

In addition, the concept of designing the joints for the stop-motion armature should be similar to the natural movements of living organisms and the principles of animation to create characters that are realistic. This is consistent with Castells and Fonseca (2009), who noted that the creation of animation characters can be linked to the archetypical concept of Carl Gustav Jung, which uses ancient personality patterns. Characters of the same type appear at any time and in every culture in history, resulting in a universal model and the exchange of experiences in different historical events.

This can be seen as a universal language, as mentioned by Floquet (2006) in the article on text theory proposed by Roland Barthes that "every text is inter-text; it holds other texts within, at various levels and in irregularly recognizable shapes. Other texts that are combined are from preceding cultures, as well as the surrounding

culture. Every text is new, with interwoven past quotations" (p. 1). A text, film, or animated film is made and framed with gathering quotations that work together in the original feature. Moreover, a text, film, or animation absorbs, transforms, and creates its own text form.

According to Harryhausen and Dalton (2008), stop-motion animation is a valuable art that can show the beauty of human emotions, craft art, and handmade art. This makes the art of stop-motion animation techniques as valuable as High Art. Further, it can be expected to endure/exist in an era of technological change.

This experimental work will be used for working in the digital content industry in Thailand by studying and developing techniques. Then, it will be applied for work in stop-motion animated movies. It is another technique and another tool which could be an alternative leading to industrial production to support the animation industry and its continuing growth in Thailand.

Acknowledgement

The researchers would like to thank the Faculty of Architecture, Naresuan University, and Government Budget Grant as well as all experts for providing comments and suggestions that make this research complete.

Funding

This research did not receive any specific grant from funding agencies in the public, commercial, or not-for-profit sectors.

References

- A9 Products (2020) *Armature nine*. Available from: <https://armaturenine.com/> [Accessed 5th June 2022]
- Animation Toolkit (2018a) *Male 1C cinematic armature anibild chimera*. Available from: <https://www.animationtoolkit.co.uk/anibild-chimera-male1c/> [Accessed 5th June 2022]
- Animation Toolkit (2018b) *Aardman armatures creature kit*. Available from: www.animationtoolkit.co.uk/aardman-armatures-creature-kit [Accessed 5th June 2022]
- Brierton, T. (2002) *Stop-Motion Armature Machining: A Construction Manual*. Jefferson, McFarland & Company.
- Brierton, T. (2018) *Princess charulata the Indian oracle armature*. Available from: <https://tombrierton.wixsite.com/website/stop-motion-armatures> [Accessed 5th May 2021]
- Castells, J. D. & Fonseca, D. (2009) Disabled personages in the full-length films of Pixar Animation Studios (1995-2006). In: *Proceedings of the 1st*

- ACM SIGMM international workshop on Media studies and implementations that help improving access to disabled users, MSIADU '09, 19-24 October 2009, Vancouver, Canada. New York, Association for Computing Machinery. pp. 13-18. Available from: doi: 10.1145/1631097.1631102
- Floquet, P. (2006) *What is (not) so French in Les Triplettes de Belleville*. Available from: <https://journal.animationstudies.org/pierre-floquet-what-is-not-so-french-in-les-triplettes-de-belleville/> [Accessed 10th June 2022]
- Harryhausen, R. (n.d.) *Armature of cyclops*. Available from: <https://www.heavymetal.com/news/ray-harryhausen-clash-titans-voyage-sinbad-scotland/> [Accessed 10th June 2022]
- Harryhausen, R. & Dalton, T. (2008) *A Century of Stop-motion Animation from Melies to Aardman*. New York, Billboard Books.
- Janma, V. (2003) *The design and development of armature mechanic for stop-motion animation*. Thailand, Naresuan University.
- Kawamura, T. (2019) *StopMate SM-004D*. Available from: <http://www.modelanimation.com/> [Accessed 5th June 2022]
- Kivy, P. (2004) *The Blackwell Guide to Aesthetics*. Hoboken, Blackwell Publishing Ltd.
- Lane, C. (2018) *Skelly the skeleton*. Available from: <https://www.thingiverse.com/thing:3064150> [Accessed 10th June 2022]
- Liu, Z. (2007) Simulation of virtual human's mental state in behavior animation. In: *Life System Modeling and Simulation, International Conference, LSMS 2007, 14-17 September 2007, Shanghai, China*. Berlin, Springer. pp. 284-291. Available from: doi: 10.1007/978-3-540-74771-0_32
- LNCollections LLC (2008) *Stikfas*. Available from: <https://i.ebayimg.com/images/g/dkAAAOSwRkh-i00iV/s-l1600.jpg> [Accessed 4th June 2021]
- Loy, J. (2018) Understanding the scope for a product design education discourse on additive manufacturing. *Archives of Design Research*. 31 (2), 15-22. Available from: doi: 10.15187/adr.2018.05.31.2.15
- ModiBot (2019) *ModiBot character design system*. Available from: <https://modibot.com/pages/meet-mo> [Accessed 8th June 2022]
- Nattotoys (2017) *Gemobot*. Available from: <https://www.facebook.com/nattotoys/photos/a.1446461742042657/1626296500725846/> [Accessed 7th June 2022]
- Shen L. F. (2007) What is "computer animation"? - Examining technological advancements and cultural aesthetics of Japanese animation. In: *Special Interest Group on Computer Graphics and Interactive Techniques Conference, SIGGRAPH'07, 5-9 August 2007, San Diego, California*. New York, Association for Computing Machinery. p. 23. Available from: doi: 10.1145/1282040.1282064
- Singh, A. & Singla, A. (2016) Kinematic modeling of robotic manipulators. *Proceeding of the National Academy of Sciences, India Section A: Physical Sciences*. 87, 303-319. Available from: doi: 10.1007/s40010-016-0285-x
- Singh, G. & Verma, A. (2017) A brief review on injection moulding manufacturing process. *Materials today: Proceedings*. 4 (2), 1423-1433. Available from: doi: 10.1016/j.matpr.2017.01.164
- Stickybones Inc. (2019) *Stickybones indiego*. Available from: <https://www.stickybones.com/> [Accessed 9th June 2022]
- Trik Film Effects (2010) "Boy" armature from the film "Within". Available from: <http://trikfx.com/armatures> [Accessed 10th June 2022]

